



Description PCA-12

Unit for precoat dosing in filter unit inlet

Construction

Tank unit with feed hose for ventilation units. Pneumatic stirring inclusive damper and automatic for precoat dosing in piping/filter unit

- Tank unit 117 L volumen
- ½-false air valve for transport air setting for precoat
- 1.5m feed hose for ventilation unit
- 2.5m (230V) timer supply connection
- 2.5m compressed air hose
- Timer: Setting from 1 sec. - 99 hours per dosing shot as well as interval time (see below)
- Compressed air supply: 6.0 - 8.0 bar
- Filled by top lid

Application

Unit used for precoat dosing in filter unit inlet, which can increase filter element life (dry up or neutralize air pollutions)

Product	Order no.	Supply voltage	Hz
PCA-12	04 398 100	24 VAC	50/60
PCA-12	04 399 100	240 VAC	50/60

Timer specification	
Discharge (ON) timer:	0.1 - 99 hours
Interval (OFF) timer:	0.1 - 99 hours
Max. power consumption:	7mA
Temperature range:	-40 - +60°C
Design standard:	VDE 01 10C
Protection rating:	IP 65 (when installed)

Further is available:

- Precoat 14.0kg in sack (04 398 500)

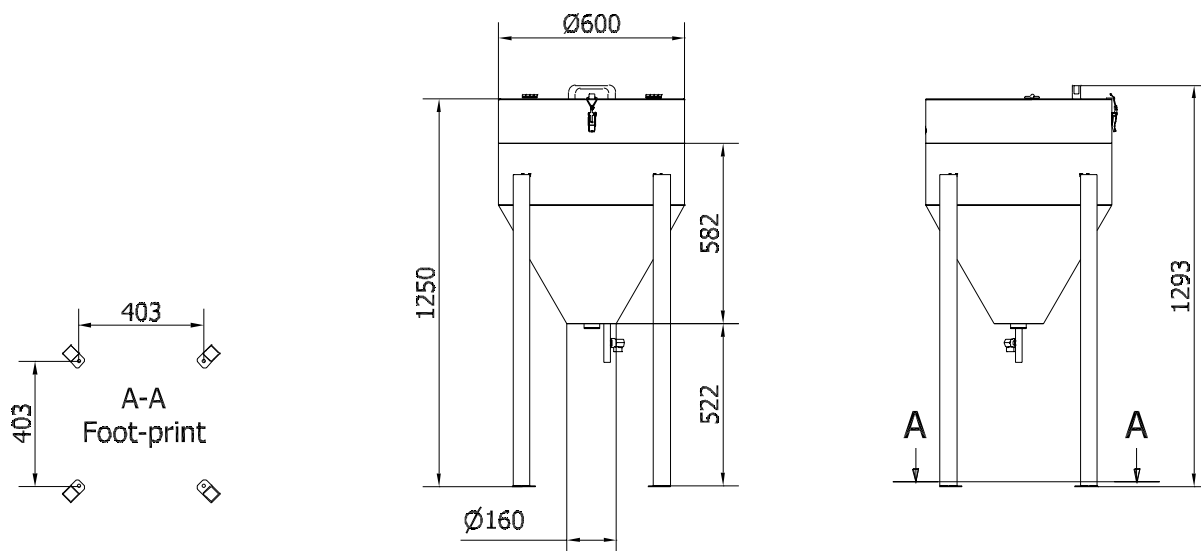

Colour: RAL 5007/7011 (structure)